



FUJI ELECTRIC

ROOM AIR CONDITIONER

RK-7AP

SERVICE MANUAL

C O N T E N T S

SPECIFICATIONS	1
CIRCUIT DIAGRAM	2
DISASSEMBLY ILLUSTRATION	3
PARTS LIST	6



Большая библиотека технической документации

<https://splitsystema48.ru/instrukcii-po-ekspluatácii-kondicionerov.html>

каталоги, инструкции, сервисные мануалы, схемы.

SPECIFICATIONS

MODEL		RK-7AP
COOLING CAPACITY	(kW)	2.10

ELECTRICAL DATA

POWER SOURCE	(V)	220	
FREQUENCY	(Hz)	50	
COOLING	RUNNING CURRENT	(A)	3.6
	INPUT WATTS	(kW)	0.78
	EER	(kW/kW)	2.69

COMPRESSOR

TYPE		Hermetic type, Rotary type	
CODE		QB134PL22A 3 Leg 220-240V 50Hz	
REFRIGERANT	R-22	(g)	540

FAN MOTOR

CODE		MFC-09BTM 220-240V 50Hz
HIGH POWER	(r.p.m.)	1,040
SUPER QUIET	(r.p.m.)	800

CIRCUIT DIAGRAM

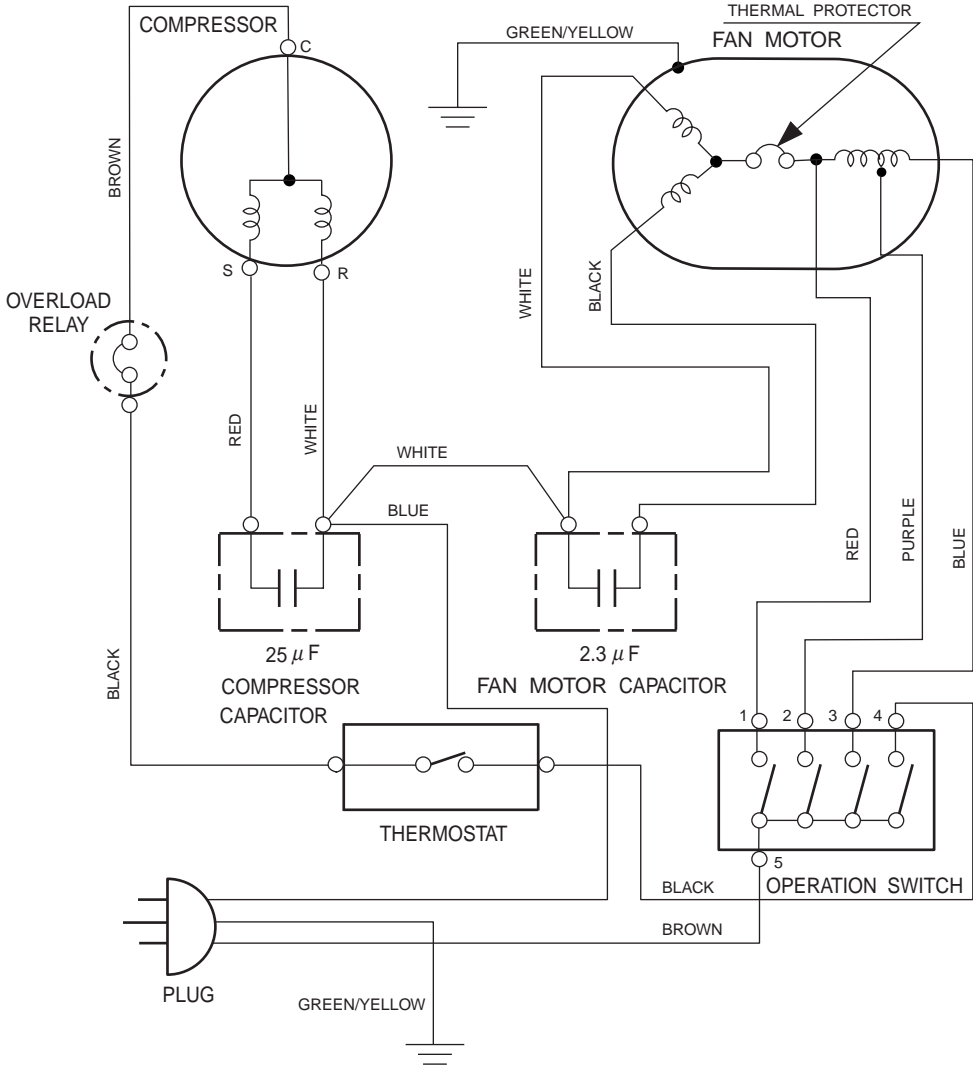

OPERATION SWITCH INTERNAL CONNECTIONS

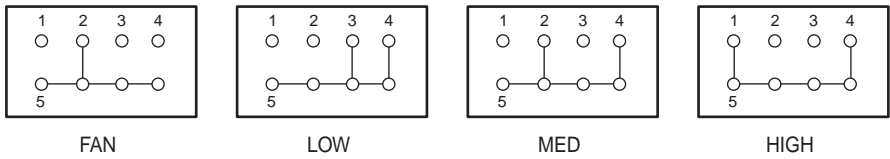

DISASSEMBLY ILLUSTRATION

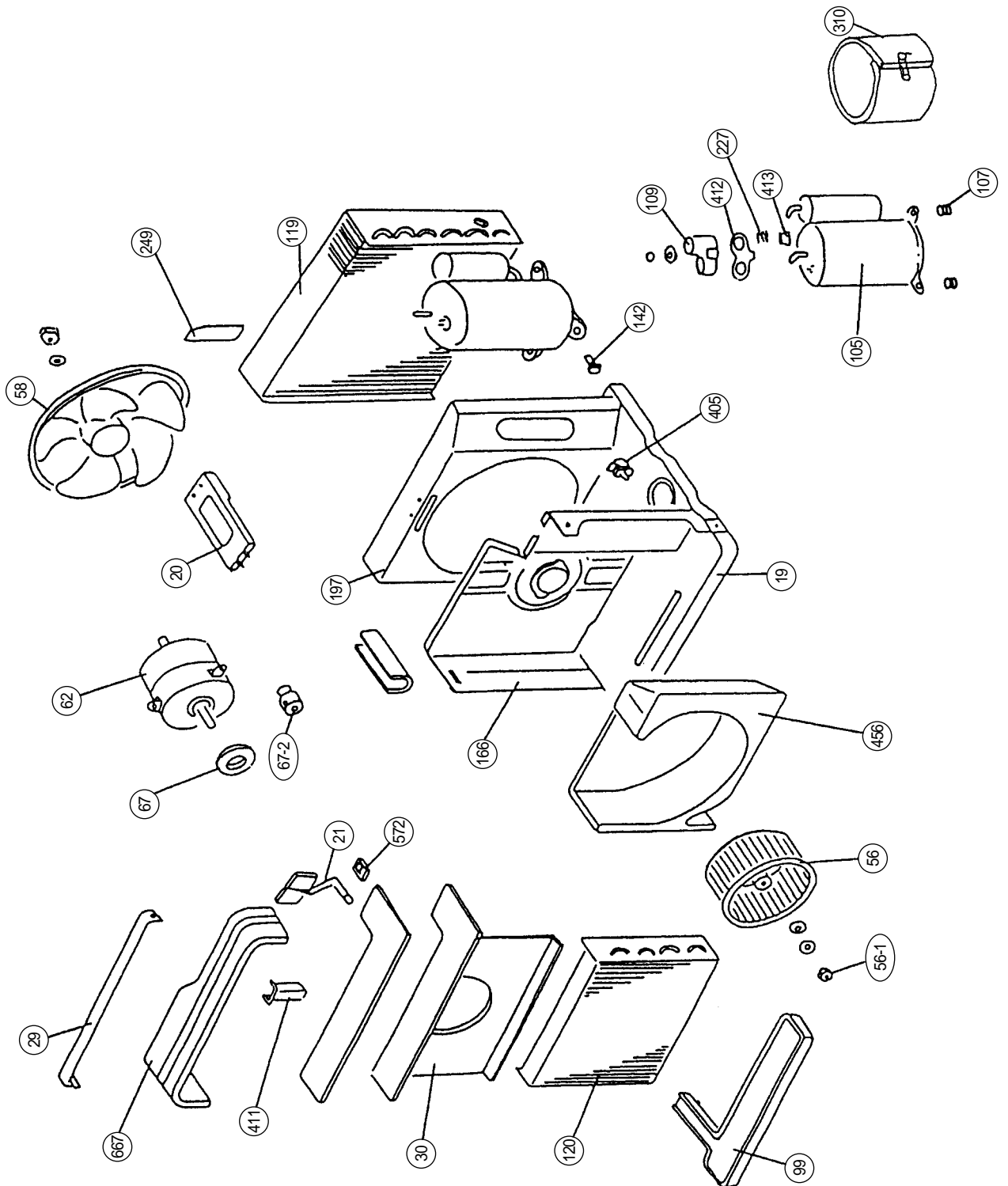

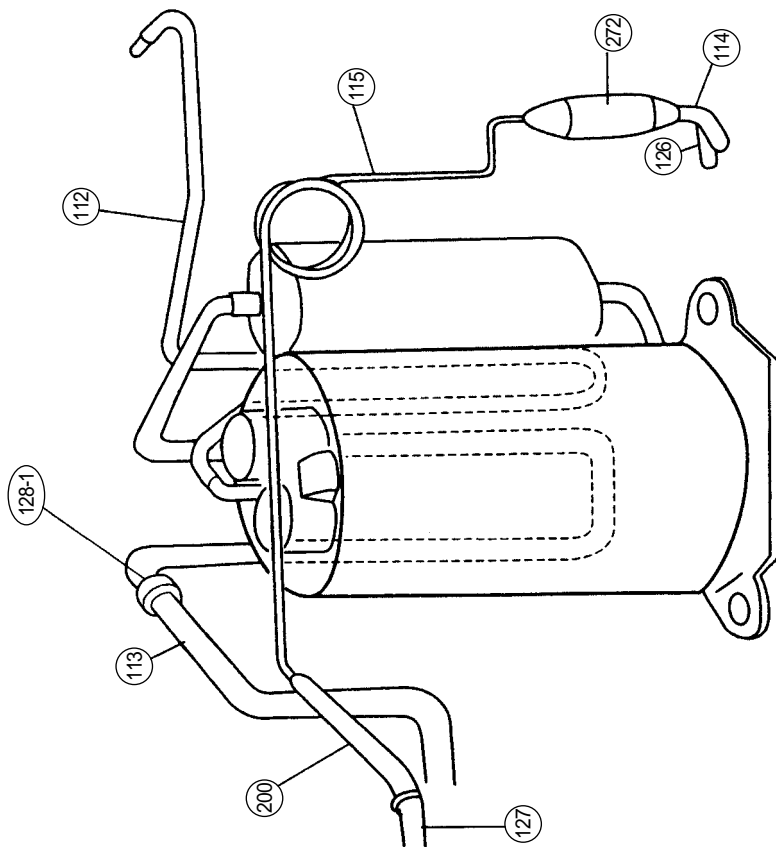
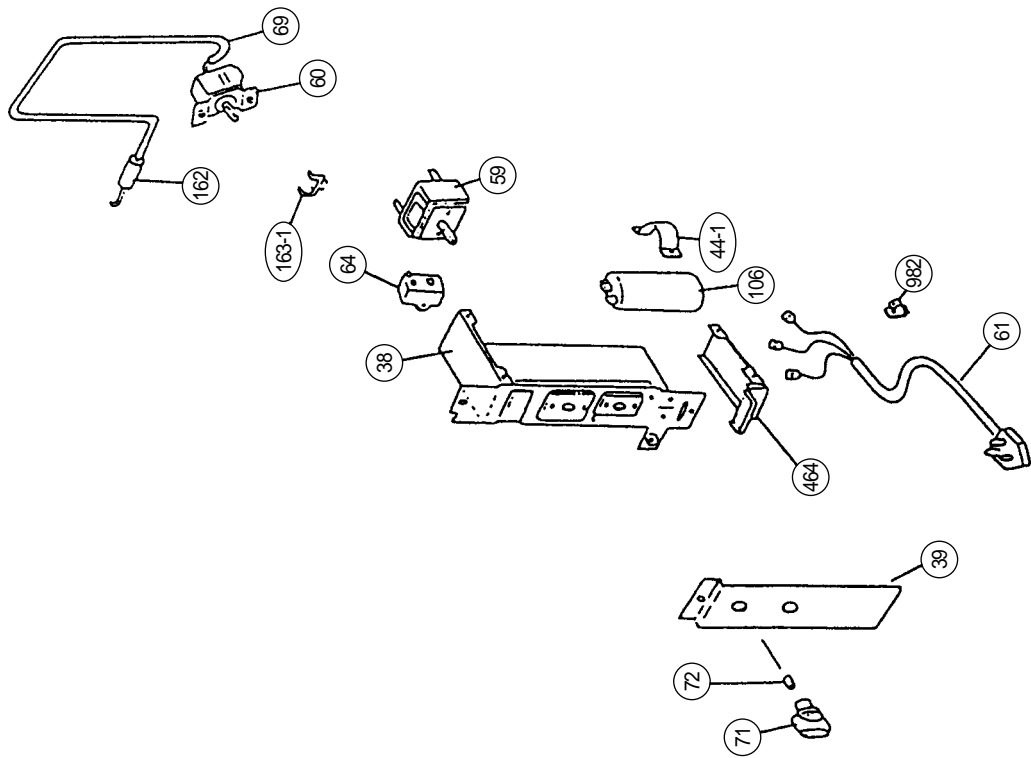

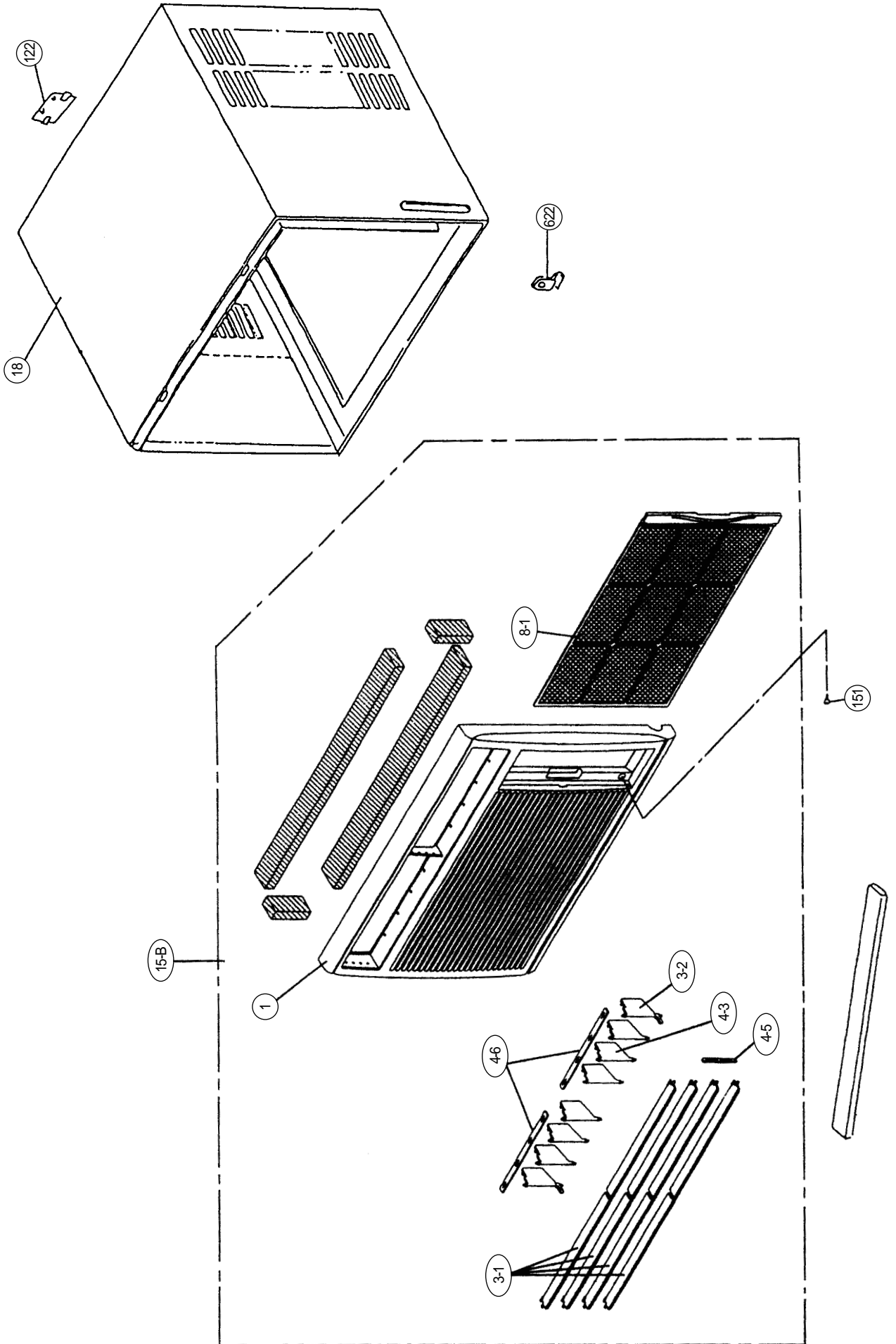

PARTS LIST

When you order parts, please make a photocopy of this page and fill the number of the parts in the "Order" column.

FRONT PANEL PARTS

Ref. No.	Description	Part No.	Ord. Q'ty	Ref. No.	Description	Part No.	Ord. Q'ty
1	Front Panel	9361838017		4-5	Connecting Plate-A	9358102015	
3-1	Louver-A	9361840010		4-6	Connecting Plate-B	9358103012	
3-2	Louver-C	9358101018		8-1	Filter	9361842021	
4-3	Louver-B	9358100011		15-B	Front Panel Assy	9362575027	

CABINET CHASSIS PARTS

Ref. No.	Description	Part No.	Ord. Q'ty	Ref. No.	Description	Part No.	Ord. Q'ty
18	Cabinet Assy	9389020067		113	Suction Pipe Assy	9362060004	
19	Base Assy	9389017081		114	Air Duct Pipe-E	313252257206	
20	Supporter-C	9358091005		115	Capillary Tube	9362061001	
21	Exhaust Air Damper	9358094020		119	Condenser Assy	9358132012	
29	Supporter-B	9358089002		120	Evaporator Assy	9358131015	
30	Blower Mouth	9358084007		122	Emblem-B (Rear)	9358104040	
38	Switch Box-A Assy	313107242805		126	Condensing Pipe-B	9358923009	
39	Switch Panel	9358134092		127	Inlet Pipe (Evaporator)-B	9359748014	
44-1	Capacitor Band (Running Capacitor)	313106061706		128-1	Rubber (Discharge Pipe)	313155086308	
				142	Drain Pipe	9351674007	
56	Sirocco Fan	9358107010		151	Front Panel Screw	313306389909	
56-1	Nut For Sirocco Fan	9358135006		162	Thermostat Holder	313616262803	
58	Propeller Fan	9358106013		163-1	Thermostat Spring-A	313668262714	
59	Operation Switch	9370012019		166	Separate Wall Assy	9358114018	
60	Thermostat	9370013016		197	Wind Guide Board	9358092026	
61	Power Cord Assy	9703286025		200	BR Sheet-B	9359189008	
62	Fan Motor Assy	9358334003		227	Terminal Spring	9359429012	
64	Capacitor (Fan Motor)	9703124013		249	Dew Proof Plate	313106041504	
67	Rubber (Vibration-proof)	313106068602		272	Strainer	9350663026	
67-2	Rubber-B (Vibration-proof)	9358306000		310	Compressor Cover	9364291000	
69	Protection Tube	313310060308		405	Clamp No. 1763	313816345304	
71	Thermostat Knob	9358105016		411	Supporter-A	9358115015	
72	Knob Spring (Thermostat Knob)	313008061010		412	Terminal Gasket (For Comp.)	9362004008	
				413	Overload Relay	9362018005	
99	Drain Pan	9358086001		456	Casing	9358082003	
105	Compressor Assy	9361734005		464	Switch Box Cover-C	9358009024	
106	Running Capacitor	9350973019		572	Holder (Ex. Air Damp.)	9358095010	
107	Rubber Seat-A (For Comp.)	9359425014		622	Bracket (Typhoon Lock)	9355799003	
109	Terminal Cover (For Comp.)	9359426011		667	Casing-Upper	9358088005	
112	Discharge Pipe	9362062008		982	Cord Clamp	9363471007	



MANUFACTURER :

Fuji Denki Sosetsu C

Tokyo, Japan



Большая библиотека технической документации

<https://splitsystema48.ru/instrukcii-po-ekspluatacii-kondicionerov.html>

каталоги, инструкции, сервисные мануалы, схемы.